

# ESOTERIC

# Grandioso C1

Linestage Preamplifier



## Specifications

### Analog audio inputs

Connectors	RCA × 2 pairs / XLR × 3 pairs (RCA 2 can be used as an AV pre-input)
Input impedance	RCA : 10 kΩ / XLR : 10 kΩ
Input sensitivity	At rated output : 510 mV
Maximum input level	12 V

### Analog audio outputs

Connectors	RCA × 2 pairs / XLR × 2 pairs
Output impedance	RCA : 47 Ω / XLR : 66 Ω
Total harmonic distortion	RCA : 0.0006 % / XLR : 0.0004 %
Frequency response	1 Hz – 200 kHz (-3.0 dB) / 3 Hz – 50 kHz (-0.2 dB)
Signal-to-noise ratio (S/N)	116 dB (2 V input, A-weight)
Gain	+12 dB
Rated output	2 V
Maximum output level	RCA : 7.5 V (1 kHz, 0.003 %) / XLR : 15 V (1 kHz, 0.003 %)

### General

Power supply	AC 230 V, 50 Hz / AC 120 V, 60 Hz / AC 220 V, 60 Hz
Power consumption	25 W
External dimensions (W × H × D) (including protrusions)	
Main unit	445 × 132 × 457 mm (17 5/8" × 5 1/4" × 18")
Power unit	445 × 132 × 451 mm (17 5/8" × 5 1/4" × 17 7/8")
Weight	
Main unit	21 kg (46 3/8 lb)
Power unit	29 kg (64 lb)

### Included accessories

Power cords × 2 / DC power connection cords × 2 / Remote control (RC-1315) × 1
Batteries for remote control (AAA) × 2 / Felt pads × 8 / Owner's manual × 1 / Warranty card × 1

This product is available in three different power supply variations shown in the chart above. Make sure that the voltage shown on the rear panel matches the AC line voltage in your area. The shape of the AC inlet and plug of the supplied power cord depends on the voltage rating and destination country.

Please note that Esoteric products are available at limited distributors in respective countries.  
"ESOTERIC" and "VRDS" are trademarks of TEAC Corporation, registered in the U.S. and other countries.  
"Grandioso" is a trademark of TEAC Corporation.  
©2014 TEAC Corporation. All Rights Reserved. All text, images, graphics and other materials on this catalogue are subject to the copyright and other intellectual property rights of TEAC Corporation. These materials shall not directly or indirectly be published, reproduced, modified or distributed in any medium. Design and specifications are subject to change without notice.

PROUDLY MADE IN TOKYO

# ESOTERIC

ESOTERIC COMPANY

1-47 Ochiai, Tama-shi, Tokyo 206-8530, Japan  
Fax: (042)356-9240  
[www.esoteric.jp](http://www.esoteric.jp)



PRINTED IN JAPAN 1014005-TECD-0198



# Grandioso C1

*Linestage Preamplifier*

*Sound, in the form of music has tremendous power to move our emotions.  
In music, the absence of sound can be as powerful as sound itself.  
By skillfully combining knowledge, technology and materials,  
we can create audio components that is capable of generating these same strong emotions.  
Then, in blissful communion with the music,  
the listener is able to forget the very existence of the audio system.  
Placing its prestige on the line,  
ESOTERIC proudly introduces an outstanding  
new preamplifier: Grandioso C1.*

MasterSoundWorks

Audio expression, symphonic beauty, artistic passion, a concert hall spatial feel, the excitement of the audience. Esoteric's Master Sound Works is an audio product concept that recreates all of the music information in original master recordings with the most state of the art technology available today.



PROUDLY MADE IN TOKYO

ESOTERIC



## Design Philosophy

The Grandioso C1 is the result of the dedication to audio quality instilled in every component that bears the proud Grandioso name. Advancing well beyond the core objective of creating “high fidelity,” in the development of the new C1 we set our sights on new summits, blending the sensibilities of the audio engineer with those of the consummate musician.

A product of uncompromising craftsmanship and the highest standards of audio fidelity, each C1 preamplifier is handmade in our Tokyo factory and fully reflects Esoteric’s underlying Grandioso philosophy. State-of-the-art circuit design and leading-edge technology combine to realize outstanding audio performance. The C1’s robust construction employs two separate chassis, with each channel totally independent from the other.



## Massive Construction

The C1’s two-chassis construction physically isolates the power supply from the audio circuitry. This allows the unit to create a sound stage having exceptional transparency, as well as providing a liberating sense of musical vibrancy, without betraying so much as a hint of stress.

The C1’s separate 29kg linear power supply enables pristinely accurate amplification and ensures that the music signal is delivered to the power amplifiers without any loss of dynamics. This gives the music the power and vibrancy to captivate the listener. Due to the C1’s monoblock internal construction, all the elements of each channel are completely independent: from the audio circuitry to the DC power supplies, and right down to the separate AC power cables. Creating the excitement of having every musical instrument accurately positioned before you, the C1 is the crystallization of an approach single-mindedly focused on accurate stereo sound reproduction.

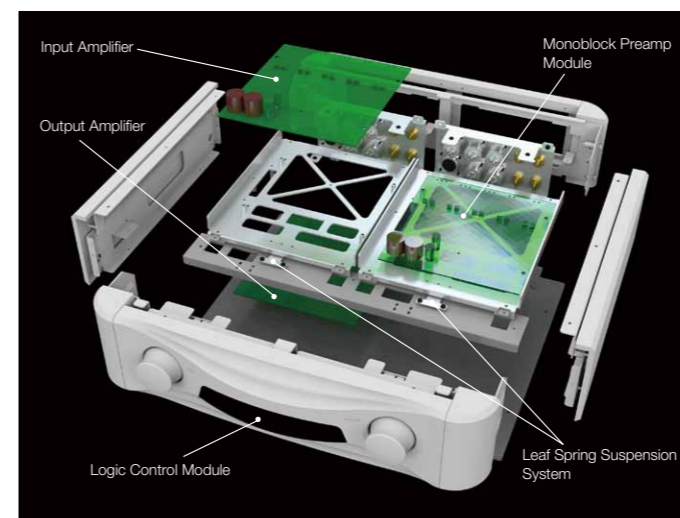

### Main Unit

The C1’s main unit consists of two monoblock preamplifier modules and a logic control module. The input and output sections of each preamplifier module are constructed on separate boards, which are arranged one above the other in order to minimize the lengths of the signal paths. These modules are mounted on a unique leaf spring suspension system that was originally developed for Esoteric’s leading lineup of SACD players. Its floating design helps achieve total left and right channel independence, and enhances the sense of spaciousness and ease in the sound.



### DC Power Supply Unit

The C1’s DC power supply features a fully independent two-channel design with dual AC inputs and DC outputs. Together with the careful selection of components one would expect in such a reference product, this produces significant improvements in sound quality. Especially notable in the power supply’s construction is the use of five generously rated power transformers, high-capacity reservoir capacitors and silicon carbide (SiC) Schottky barrier diodes.



## Circuit Design

All sections of the amplification circuitry are fully balanced, with the input buffer, volume control and high-speed output buffer laid out three-dimensionally to achieve the shortest possible signal paths. The C1's DC power supply provides a clean and stable output to each preamplification section, ensuring that the power amplifiers maintain full control of the loudspeakers, while at the same time preserving the music's delicacy and dynamics.

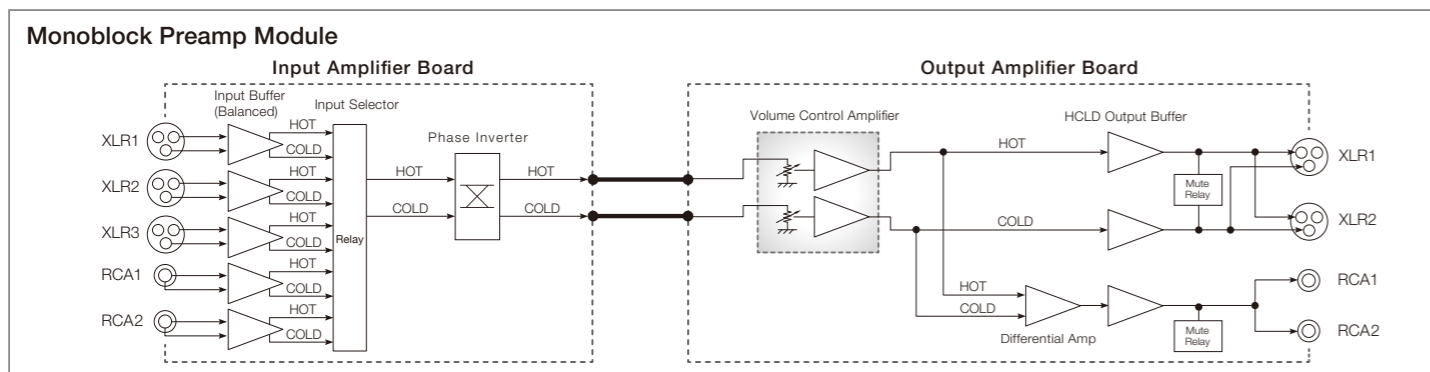
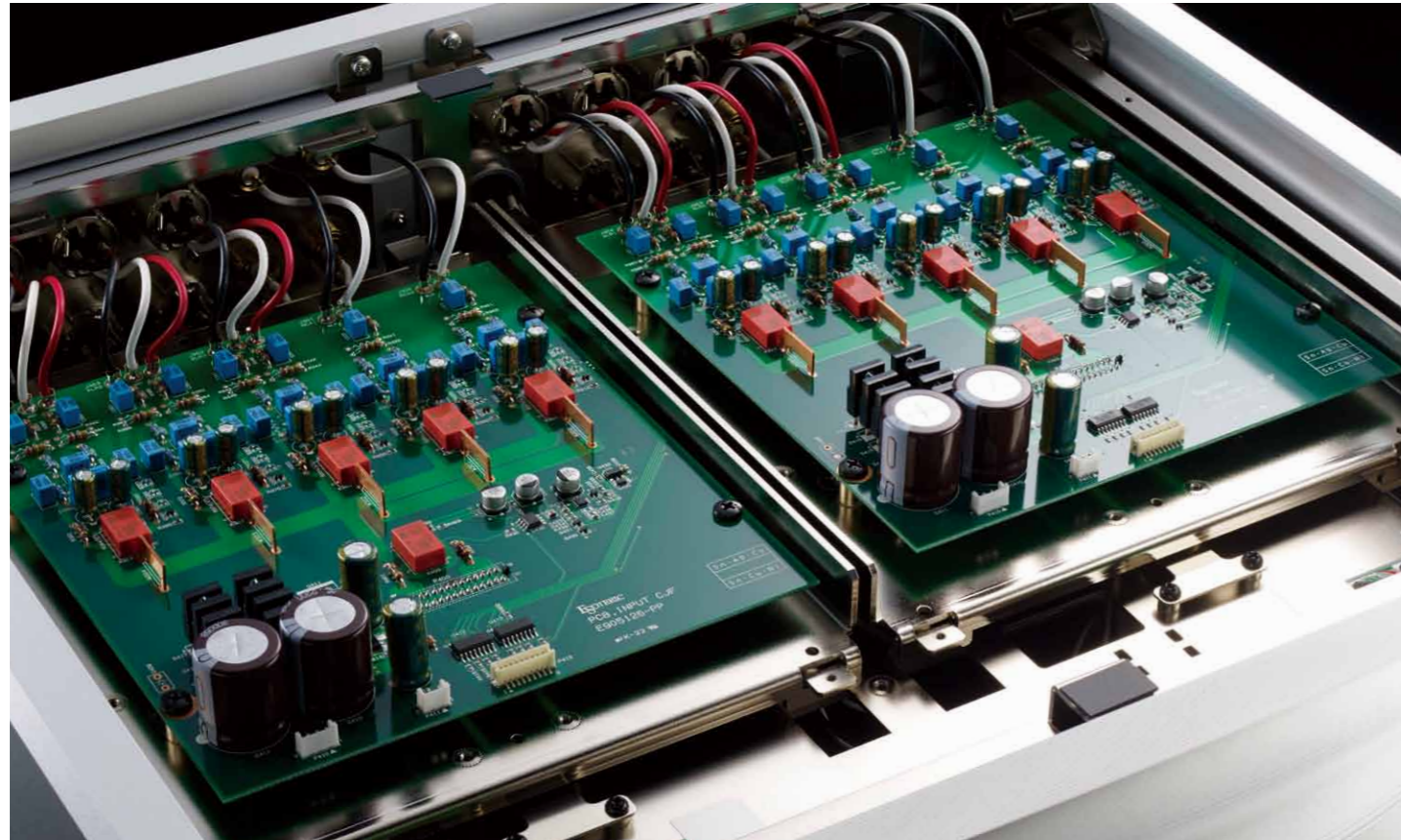

### Fully Balanced Configuration

The C1's source signal is first received by the dedicated buffer amplifiers integrated with each of the five inputs (XLR x 3, RCA x 2), and the circuit configuration is balanced at each stage from there on. Through the elimination of common-mode noise and the reduction in circuit impedance, a pure signal, free from noise, is fed to the gain amplifiers via the shortest possible path.

The C1's volume control features the Esoteric-QVCS.\* This employs four

precision switched resistor ladder networks, which change in unison when the volume knob is rotated. This arrangement allows the signal paths for the left and right channels and the positive and negative phases to be kept totally independent and as short as possible. Consequently the sound has superb clarity, excellent channel separation and a highly accurate phase characteristic.

\*QVCS = Quad Volume Control System

### Advanced Output Buffer Circuitry Delivers Stronger Performance to Drive Power Amplifiers — ESOTERIC-HCLD\*

In its function as a line driver, the preamplifier must have the ability to fully drive the power amplifiers in a way that faithfully conveys music signals that have an extremely wide dynamic range, extending all the way from pianissimo to fortissimo. The key to achieving this is having a circuit with both a high current drive capability and high speed. The C1's output buffer circuitry utilizes high-performance components to deliver a very high level of current drive, together with an exceptionally high slew rate of 2,000V/μs. Each output has its own independent drive circuit, and for the XLR outputs, the instantaneous output current capability is maximized by the use of fully symmetrical circuitry for both the hot and cold phases.

The C1 employs an EDLC\* Super Capacitor array located close to the output buffer circuitry to function as a highly stable power source. Its compact physical size belies the fact that it provides the extraordinary capacity of 100,000μF (0.1F) for each channel, facilitating very high levels of instantaneous output power, which in turn provides strong and solid bass reproduction. With the integration of these two technologies, the C1 recreates a breathtaking level of audio reality by preserving the musical dynamics that would otherwise be lost if smaller current transmission levels were employed between the preamplifier and power amplifiers.

\*HCLD = High Current Line Driver \*EDLC = Electric Double-Layer Capacitor

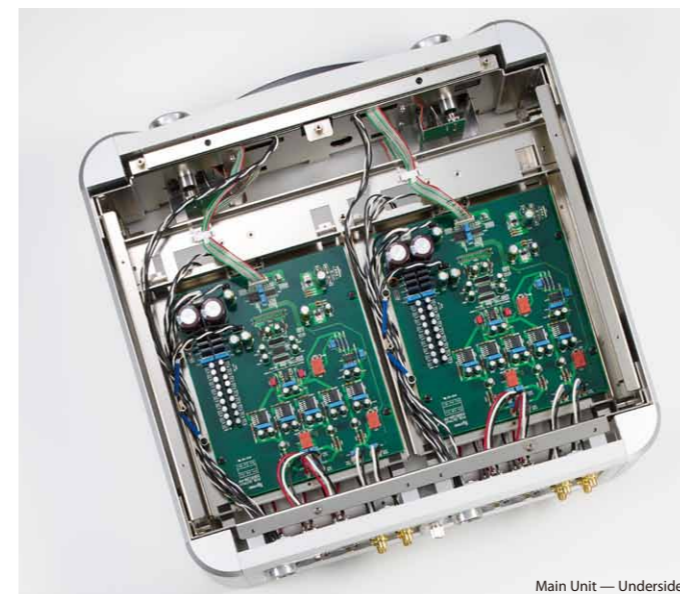
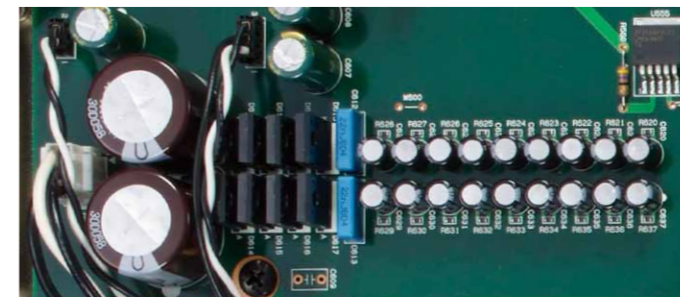

### Ultra-Low-Noise Logic Control

The logic control section is built into the front panel and is totally isolated, both physically and electronically, from the preamplifier module by the use of an optocoupler. The logic control further ensures low-noise operation by completely shutting down when not in actual operation, totally eliminating any possible influence on the C1's audio circuitry.

## Advanced Function

### Precision Controls Offer Outstanding Operational Feel

The C1's input selector and volume knobs are machined from solid blocks of aluminum. The use of a VRDS drive mechanism bearing system for the control shafts enables silky smooth rotation with absolutely no mechanical play in their movements. Rotational torque has also been fine-tuned to provide the luxurious feel of a precision analog control, in keeping with this top-of-the-line preamplifier.

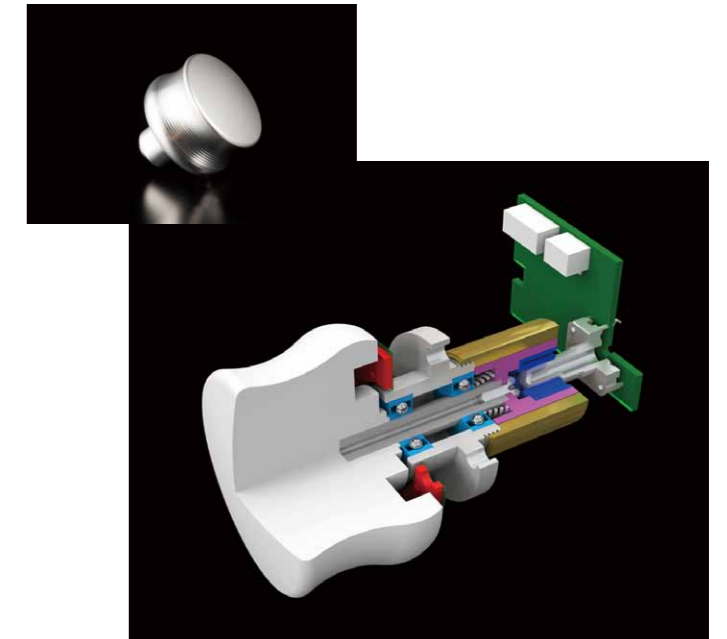

### Other Important Features

- Five preset volume curves permit selection of the most comfortable operating feel for the control.
- Adjustable individual input gains allow differences in volume between sources to be minimized. (Range: ±18dB; 0.5dB steps)
- Adjustable left and right channel volume balance control. (Range: ±6dB; 0.5dB steps)
- Selectable phase inversion can be individually set for each source.
- 'RCA 2' terminal permits switching between normal line output and AV-through output, providing added convenience for systems which are operated in both AV surround and pure two-channel modes.
- High-quality aluminum finish remote controller can also be used to operate any of Esoteric's superb line of Super Audio CD players.
- Source component name displays can be programmed using the remote controller.
- Dimmer, mute, and auto-display-off functions also provided.